



Facebook

Air balancer

CT.0002.00

Product Information

General characteristics

General Definition

Air balancer is an auxiliary device for regulating the pressure of mechanical parts under dynamic conditions

Working Principle

It is sealed by the pressure in the return direction, that is, the fluid can pass freely when the pressure difference is negative. When the pressure difference is positive, the duckbill anti-reverse valve in the air balancer prevents the backflow.

Description of Use

This product can be used in situations where one-way exhaust and pressure adjustment are required

Design and Assembly

Feature

CT.0002 series design consists of plastic shell, duckbill valve and sponge.

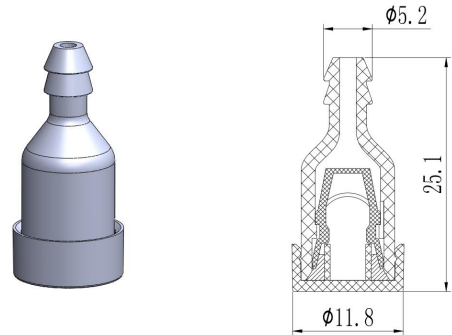

Mounting Instructions

Put the hose over the pagoda-type nozzle of this product ,please contact us for mounting instructions

Available Product Numbers

Part Number	Material	Color	Availability
CT.0002.00	NBR+POM+SPONGE	Custom	Sample & Lot

Contact:

sales-1@valvekingdom.com

website : www.valvekingdom.com

