



DIAPHRAGM CHECK VALVE

CT.0028.00

Product Information

General characteristics

General Definition

Diaphragm valve is a kind of check valve assembly under different pressure.

Working Principle

It is a seal in the return direction by pressure, that is, the fluid can pass freely under a positive pressure difference. When the pressure difference is negative, the diaphragm in the diaphragm valve prevents the backflow.

Description of Use

This product can be used in situations requiring unidirectional exhaust But different pressures



Facebook

Design and Assembly

Feature

CT.0028 series design consists of plastic casing and rubber diaphragm

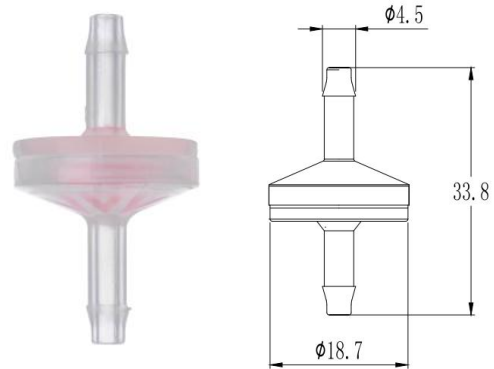

Mounting Instructions

Put the tube/hose over the barbed port of the Valve

Available Product Numbers

Part Number	Material	Opening Pressure (mbar)	Color	Availability
CT.0028.00	ABS+ SIL	20	Customize	Sample & Lot

Contact:

sales-1@valvekingdom.com

website : www.valvekingdom.com

Opening Pressure

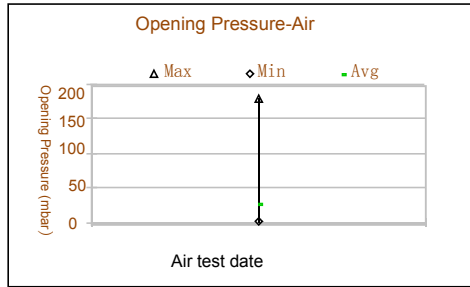

Water Test Data
Available On Request

Opening Pressure is defined as the differential pressure at which the forward flow through the valve reaches the flow threshold. Opening Pressure will increase as the flow threshold is increased, and will decrease as the threshold is decreased.

Reverse Leakage

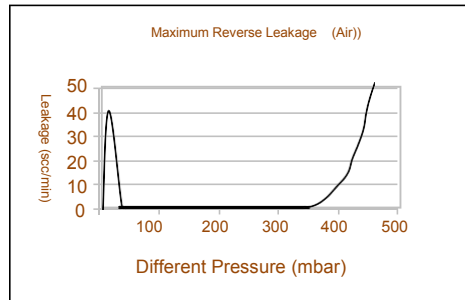

Water Test Data
Available On Request

Leakage, or flow in the reverse direction, is measured while increasing the back pressure across the valve, starting from zero. Please note that leakage graph is on a different scale from those of flow.

Forward Flow

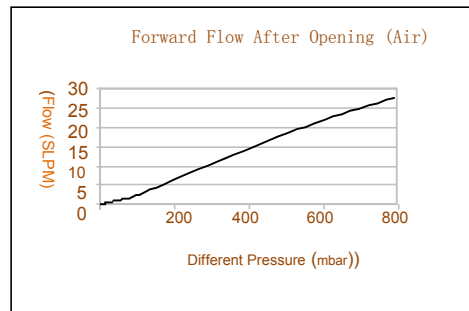

Water Test Data
Available On Request

Flow and differential pressure are measured simultaneously while increasing the inlet pressure, starting from zero. After reaching a maximum flow, the pressure is reduced to zero while measuring flow and differential pressure. The chart shows the minimum and maximum flows measured during the tests of multiple samples at each pressure.

For Conversion Purposes: 1 mbar = 1 hPa »1 cm of water

Disclaimer: Product performance is performed under Jingteng laboratory conditions and is only relevant to tested samples. The test data in this document is for general reference only. For specific media and temperature conditions, please contact Jingteng.

Contact:

sales-1@valvekingdom.com

website : www.valvekingdom.com